



Top Pro Specification Sheet

VIVREAU®



Top Pro

Countertop or Floorstanding

- Two installation options: Countertop or Floorstanding
- HygienePlus solution: designed for environments where hygiene is of the utmost importance, and is optionally available for Vivreau Top Pro.
- Vivreau's ThermalGate™ feature protects against retrograde contamination from external sources
- Sustainable: high energy efficiency and natural refrigerant R290, harmless to the climate
- Intuitive display choice of touch or mechanical buttons to select water type
- Easy Access Panel, available as an additional control unit that can be positioned at different heights, e.g. B. for wheelchair users
- Easy to use: water in 2 individually adjustable portion sizes



Installation Requirements:

Millwork

Worktop cutout on page 6

Plumbing

Water Connection

1 potable ½” cold water supply terminating in a ½” ball valve with a ½” female pipe thread.

Waste Water Connection (optional):

Option 1. Waste water pipe:

trapped up stand to facilitate a ½” flexible pipe (customer supplied). Max. 6 ½” left or right of the system

Option 2. Waste water container: available for purchase

Water Supply

- Minimum water pressure 50 PSI
- Minimum water flow 80 Gallons per hour

Electrical

(1) 20amp electrical circuit GFCI recommended (NEMA 5-20R) 120V, 60Hz (8 amps)

CO2 (Customer supplied)

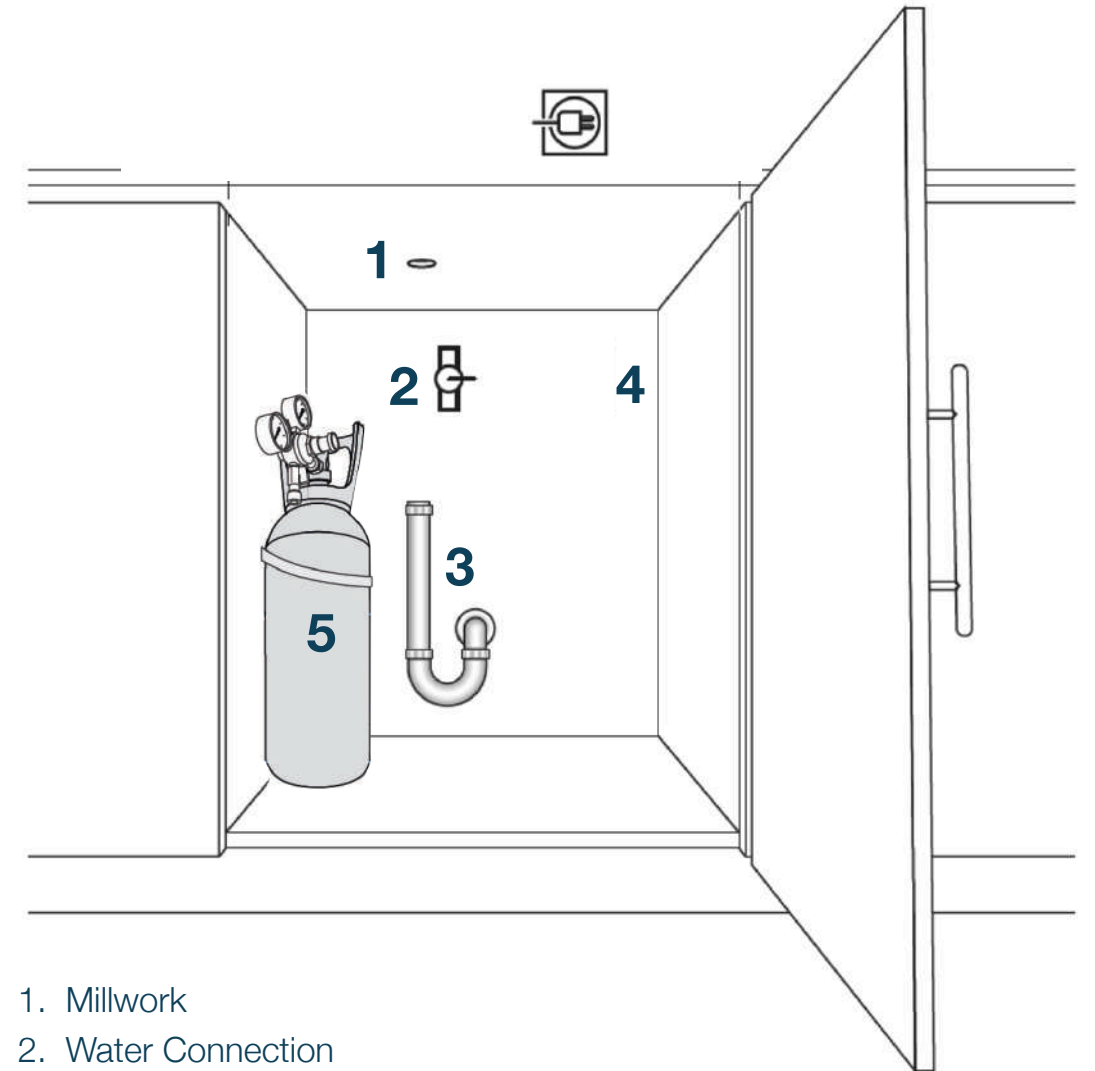

1. Millwork
2. Water Connection
3. Waste Water Connection (optional)
4. Electrical Connection
5. CO2 (customer supplied)

Easy Access Panel – Optional

Two installation options:

- Angled
- Flat: on countertop / Flat: on cabinet front



Angled installation requires a $\frac{5}{8}$ inch hole

Flat installation requires a $2\frac{3}{4}$ inch hole

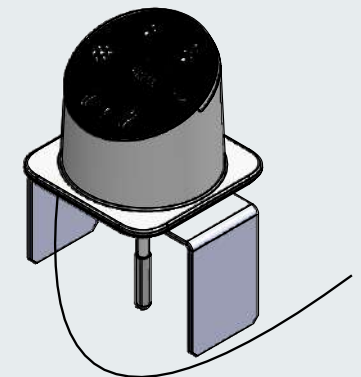
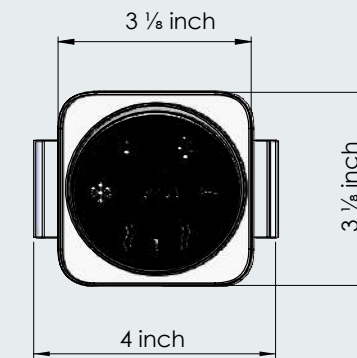
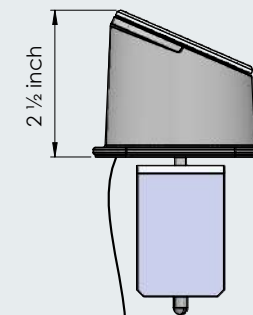
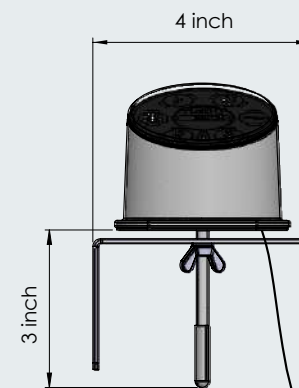

Cable 39 inch, attached

Top Pro Floorstanding

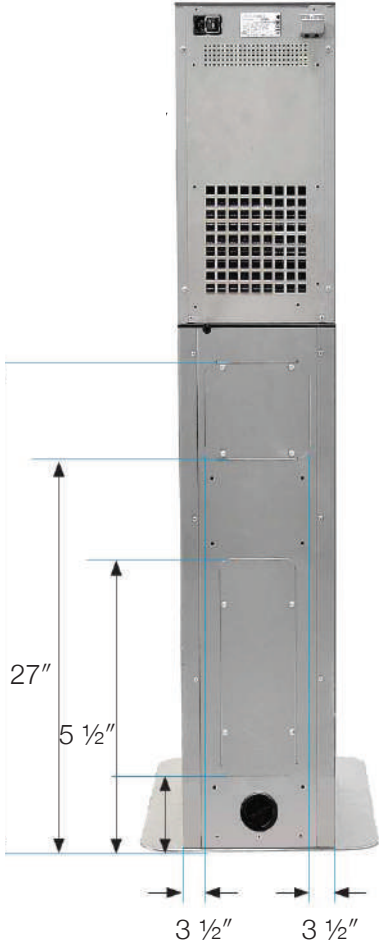
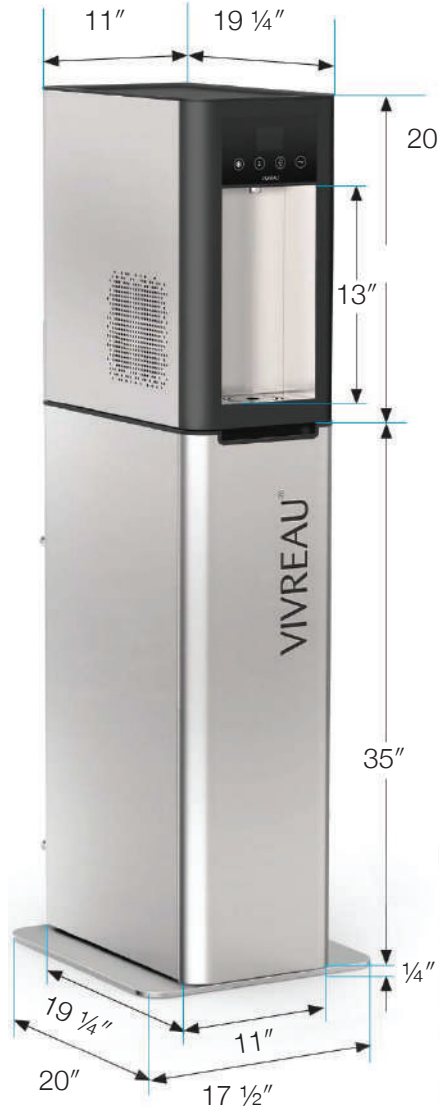

Top Pro Countertop

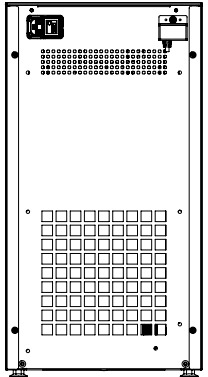
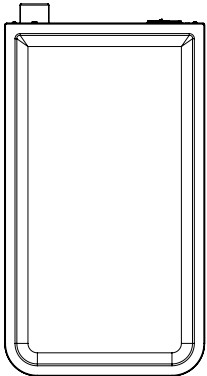
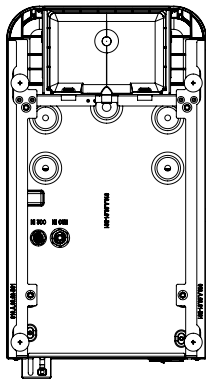
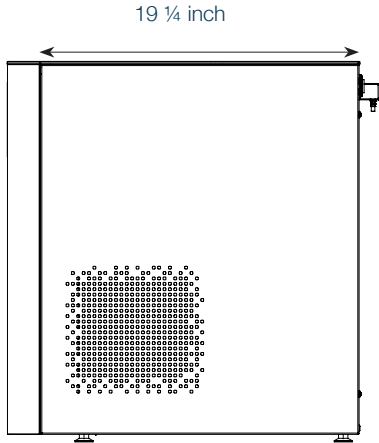
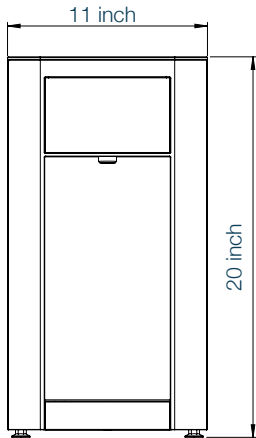

Top Pro
Worktop Cutout

THIS DRAWING IS NOT TO SCALE

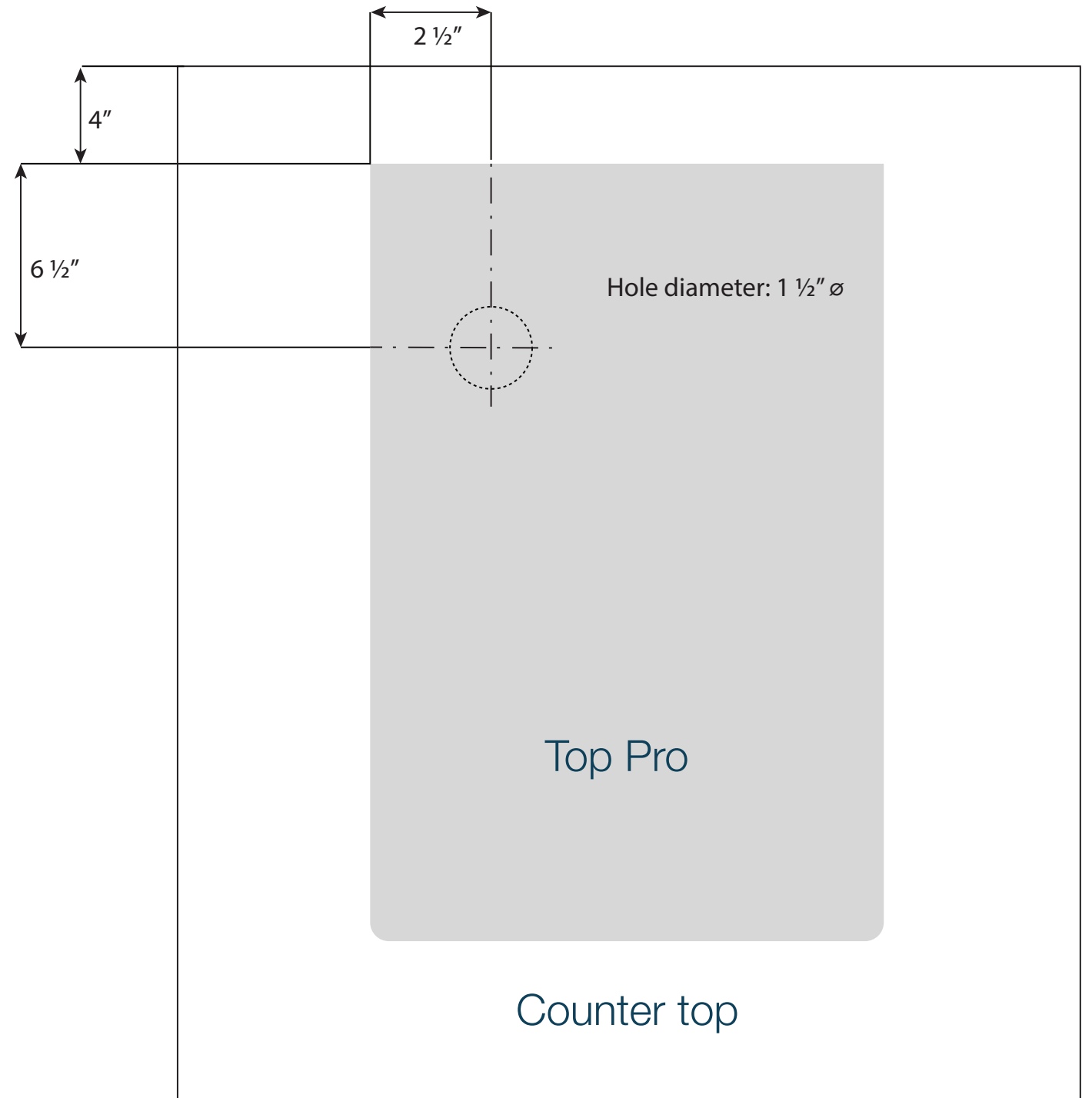
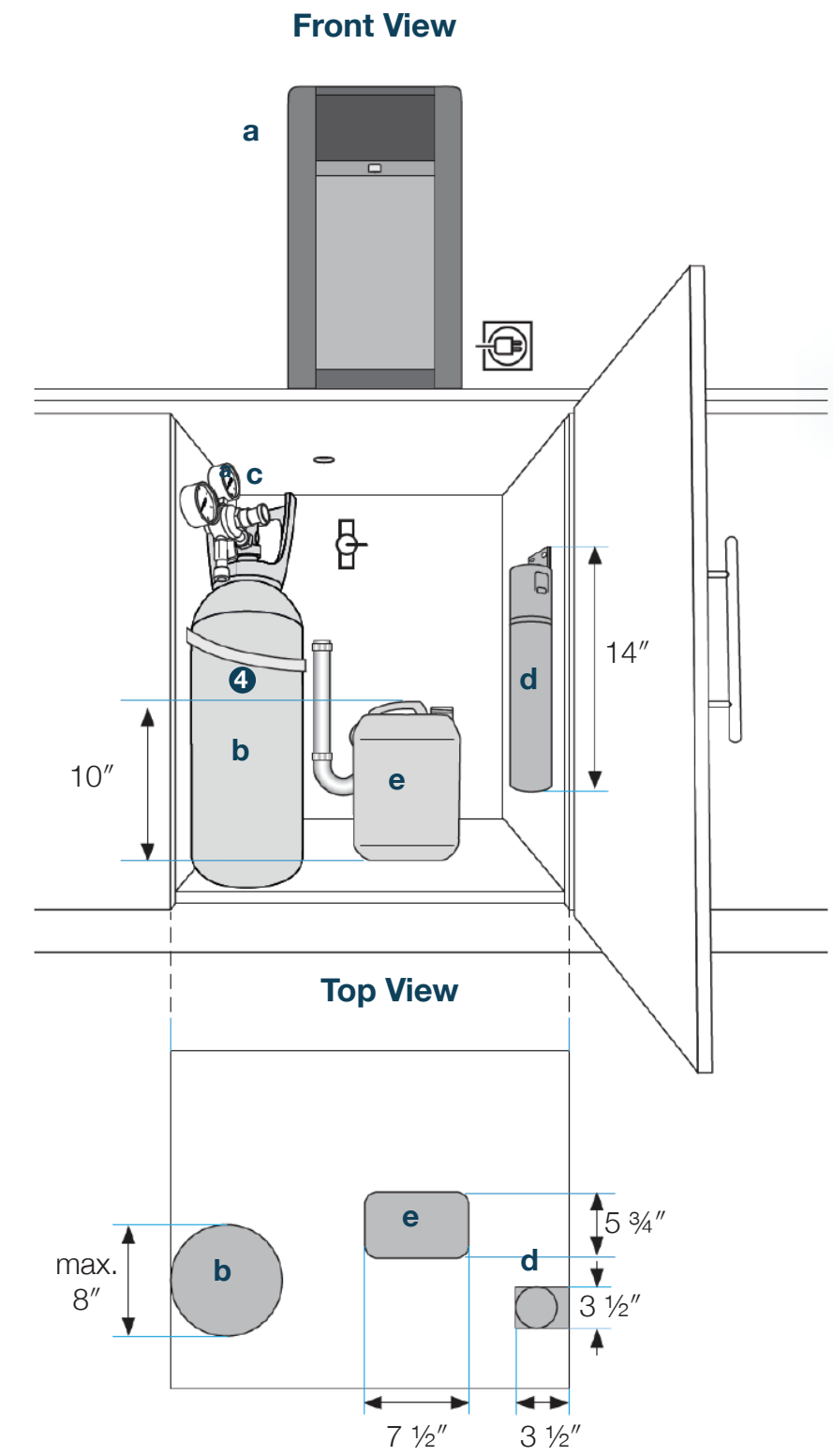
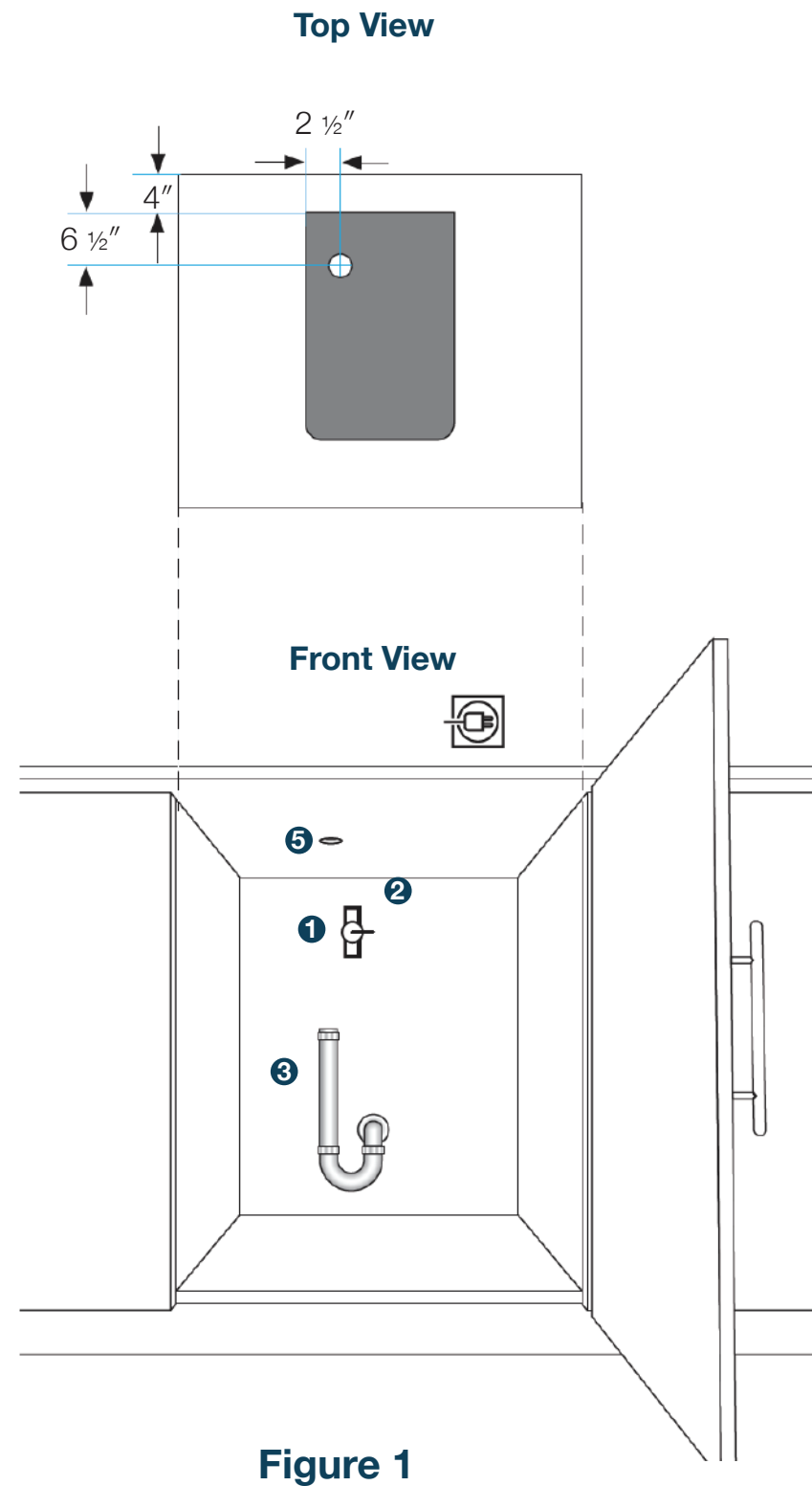

Figure 1: Installation Requirements

- 1 Water Connection
- 2 Electrical Connection
- 3 Waste Water Connection (optional)
- 4 CO2 (customer supplied)
- 5 Countertop cutout for tap

Figure 2: Arrangement and Dimensions

- a. Vivreau Top Pro
- b. CO2 Tank
- c. CO2 Pressure Regulator
- d. Filter
- e. Optional Waste Water Container





VIVREAU[®]

ADVANCED WATER SYSTEMS

Contact Info

Phone Number:

+1 877 999 1044

Email:

InfoUSA@vivreau.com

InfoCanada@vivreau.com

Or visit vivreauwater.com